

3-GALLON SPOT-XTRACT WITH HEAT

By Sandia Products

Please fill out the following information:

Model No: _____

Serial No: _____

Distributor Name: _____

Distributor Phone No: _____

Date of Purchase: _____



Built With Pride
in the USA

UnoClean

888-226-2724

SAFETY, OPERATION AND MAINTENANCE MANUAL WITH PARTS LIST

Please read before use!

100 CFM, 804 WATT MOTOR

REGISTER
YOUR
MACHINE
ONLINE!



Model No. 50-4000

IMPORTANT INFORMATION AND SAFETY INSTRUCTIONS

Register your Machine at www.sandiaplastics.com/registration.aspx

Serial No: _____

3-GALLON SPOT-XTRACT WITH HEAT

Reliable Power

Fastest Pick-Up

Safe & Easy to Use

Innovative Design

Super Lightweight

Patented Features

8.0 Machine Parts List

Drawing No.	Item ID	Item Description	Qty. Needed
1	SP-3-ST-BLKGRAN	3-Gallon Solution Tank - Black Granite	1.00
2	SP-3-RT-GRYGRAN	3-Gallon Recovery Tank - Gray Granite	1.00
3	10-0383	6-32 x 1/4" Phil Pan Screw	6.00
4	10-0400-D	Latch for Sniper	1.00
5	10-0412	C-Channel for Spotter Handle	2.00
6	10-0414	Rivet for Spotter Handle	4.00
7	10-0384	.125 Thick Nylon Washer	4.00
8	10-0385	.06 Thick Nylon Washer	4.00
9	10-0074	Flat Washer #8 SAE	11.00
10	10-0216	Allen Head Screw for Backpack	4.00
11	10-0379	8-32 x 3/8" Screw	4.00
12	10-0405	1-1/2" PVC SCH40 Slip Thread	1.00
13	10-0302-A	Hatch Cover Gasket for Spotter	1.00
14	10-0416-A	1-1/2" Black ABS Stand Pipe	1.00
15	10-0304	Spotter Cap and Float Assembly	1.00
16	10-0419	Screw for Spotter Hatch	6.00
17	SP-3-HS-BLKGRAN	3-Gallon Heater Skirt - Black Granite	1.00
18	10-0831	S/R Bracket for Sniper	1.00
19	10-0832	S/R Strap Bolts	2.00
20	10-0300	55 psi Pump for Spotter	1.00
21	10-0403-M	1/8" Brass Male Nipple	1.00
22	10-0901	175 psi Relief Valve for Heater	1.00
23	10-0510	1/8" Brass Plug	1.00
24	80-0017	Bulk Head fitting for Sniper	2.00
25	80-0024-B	1/4" MPT x 3/8" Barb	4.00
26	10-0826	3/4" Hose Clamp for Sniper	6.00
27	10-0843	3/8" Black Hose for Sniper	1.00
28	10-0434	Threaded Hose for Spotter	1.00
29	10-0407	1/8" Strait Nylon Barb NPT	2.00
30	10-0845-2	1/8" Strainer for Spotter	1.00
31	10-0301	L Bracket for Spotter	1.00
32	10-0828	90 Degree Brass Fitting for Sniper	1.00
33	10-0022	Shoulder and Waist Belt Screw	3.00
34	10-0017	Deflector Screw	1.00
35	T-C-011	Female Terminal Connector	
36	T-WPUR	Purple Wire	
37	80-0011-2	90 Degree Street Elbow	1.00
38	80-0010	1/4" Brass Tee	1.00
39	10-0843	3/8" Black Hose for Sniper	1.00
40	10-0852	1/4" 90 Degree Brass Elbow	1.00
41	80-0101-M	1/4" Male Check Valve	1.00
42	80-0014	3/8" B x 1/4" F 90 Degree	1.00
43	10-0479	1/4" Male Close Nipple	1.00
44	10-0870	1/4" Male QD	1.00
45	10-1500-B	Heater Element 600 Watt	1.00
46	10-0814	Senor for Sniper Heater	1.00
47	10-0814-B	Manual Sensor for Heater	1.00
48	10-0907	Strain Relief for Tube Heater	1.00
49	10-0906	Box for Tubular Heater	1.00
50	10-0900	Heater Body Tubular	1.00
51	10-0801-G	Pipe Wrap Insulation for Heater	1.00
52	SP-3-H-BLK	3-Gallon Spotter Handle - Black	1.00
53	10-0387	5/16" x 1" Spotter Wheel Bolt	2.00
54	10-0303	Roller Blade Wheel for Spotter	2.00
55	10-0822	Exhaust Grate for Sniper	2.00
56	10-0419-A	Screw for Sniper Hatch	2.00
57	10-0014	Motor Screw	2.00
58	10-0380	10-32 x 3/8" Screw	2.00
59	10-1024	Motor Mount Plate for Spotter	1.00
60	10-0354	3 Gallon Spotter Motor	1.00
61	10-0386	Stamped Motor Screen	1.00
63	10-1030	Spotter Motor Gasket	1.00
64	10-0027-A	Strain Relief Nut	1.00
65	T-WBLA	Black Wire	
65	10-0027	Pigtail Strain Relief	1.00
66	10-0448	20-Foot Spotter/Air Mover Cord	1.00
67	10-0025	On/Off Switch	3.00
68	10-1026	Switch Plate for 3-Gallon w/ Heat	1.00
69	10-0400-C	Keeper Latch for Sniper	1.00
70	80-0022-A	Screw for 500 psi Panel	2.00
71	10-0204	Motor Mount Back-Up Washer	2.00

Dear Valued Customer,

Congratulations on the purchase of your 3-Gallon Spot Extractor with Heat carpet and upholstery machine! The world of carpet cleaning is becoming more high-tech and competitive and we strive to provide you with the most innovative products. Our spot extractor with heat is yet another example of this, bringing a new dimension to carpet and upholstery cleaning with its cutting-edge features, quality and value.

Please review this manual, paying careful attention to the Safety Instructions section. Keep in mind that any unnecessary damage, neglect or abuse of this machine will void your warranty. You can be confident that simple maintenance will ensure that your spot extractor with heat provides quality performance for many years to come.

If warranty questions arise, please consult your manual or contact your distributor. Should you have any questions regarding maintenance, replacing parts or ordering parts, please call an authorized distributor.

Before you begin using your Spot Extractor with Heat, please thoroughly review the Owner's Manual.

Again, congratulations on the purchase of your 3-Gallon Spot Extractor with Heat carpet and upholstery machine!

7.0 Machine Schematic Drawing

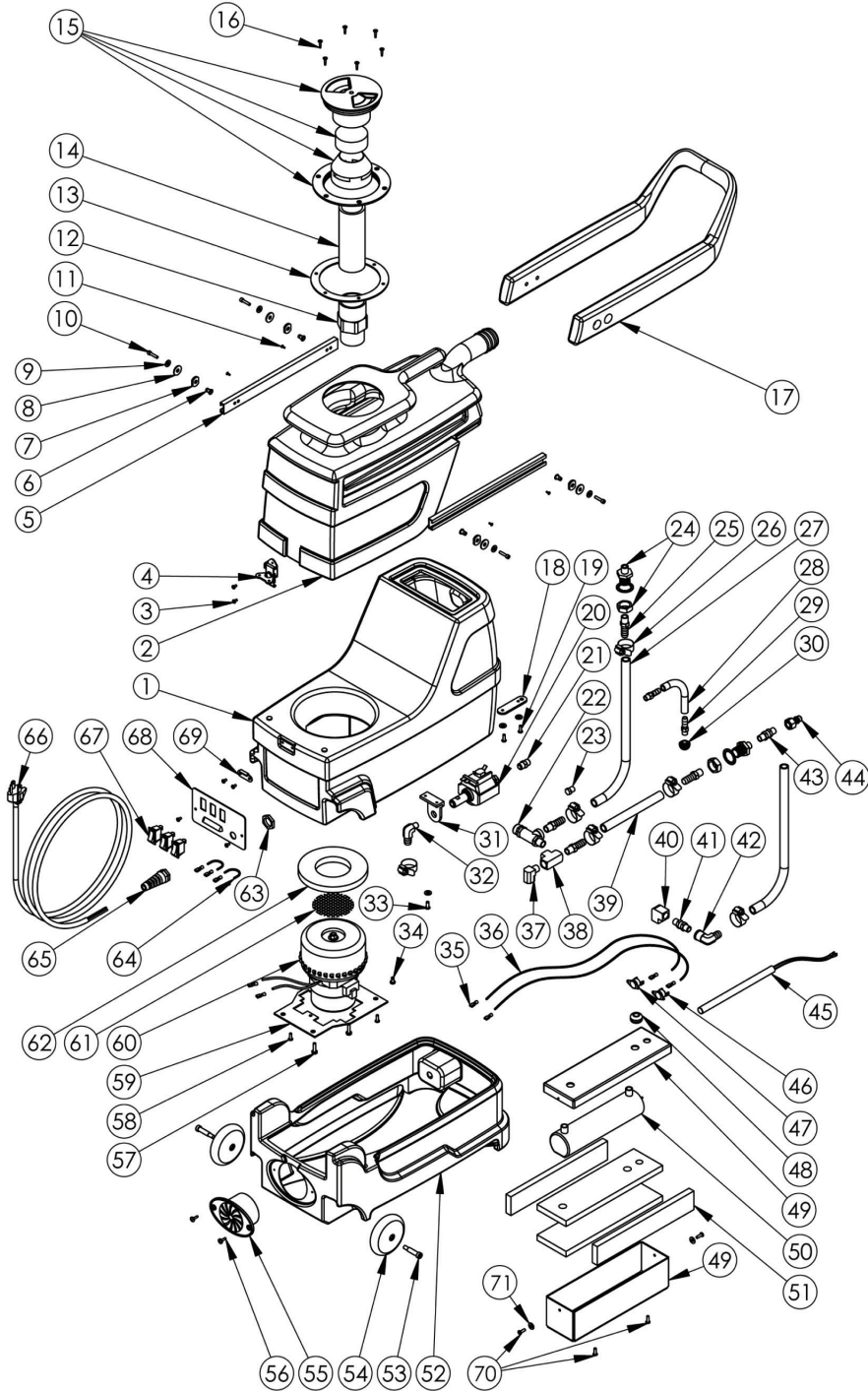

Table of Contents

- New Equipment Warranty4
- Returned Material Authorization (RMA) Procedure5
- 1.0 Safety Instructions5
- 2.0 Set-Up / Prepare Unit for Use5
- 3.0 Problem Solving.....6
- 4.0 Grounding Instructions7
- 5.0 Wiring Diagram8
- 6.0 Hoses and Hand Tool Drawing and Parts List.....9
- 7.0 Machine Schematic Drawing10
- 8.0 Machine Parts List11

New Equipment Warranty

Lifetime on molded components, 5-years on vacuum motor, 5-years on pump, 5-years on all electrical components.

Warranty Policy

All equipment is inspected and tested before shipping from the manufacturer. All parts are warranted to be new and free from defects in workmanship and material, under normal use to the original retail purchaser. This warranty limits manufacturer's liability for defects in workmanship or materials for replacement of defective parts only. Manufacturer accepts no liability for incidental or consequential damages arisen from the use of any equipment, defective or not. This warranty is in lieu of all expressed or implied warranties and is extended only to the original retail purchaser. Manufacturer sales and service representatives are not authorized to waive or alter the terms of this warranty, or to increase the obligations of the manufacturer under the warranty. Parts replaced or repaired under this warrant are warranted for the remainder of the original warranty period.

Freight charges and travel charges to and from the service provider shall be covered for ninety (90) days from the purchase date. After the ninety (90) day period, these freight charges shall be paid by the equipment owner, subject to manufacturer discretion. Certain circumstances may require additional consideration. No travel charges shall be covered after ninety (90) days.

Manufacturer covers up to 1-year (365 days) of service labor at manufacturer's calculated hourly labor rate/repair time when performed by a manufacturer's authorized-service provider. Ultimately, labor reimbursement costs are at the discretion of the manufacturer. After 1-year, original retail purchaser is responsible for all labor costs with no manufacturer reimbursement.

Manufacturer charges a 15% restocking fee for any items that are being returned to stock. Items must be new, unused and free of damage. Only good for up to 1-year. After 1-year, manufacturer does not accept the return of any item(s) for a reimbursed price.

Authorized warranty replacement parts need to come directly from the manufacturer. Any use of any other parts will void warranty. Sandia Products, Inc. does not reimburse for parts used by the customer that were not supplied directly for the machine under warranty.

6.0 Hoses and Hand Tool Drawing and Parts List

Schematic Drawing

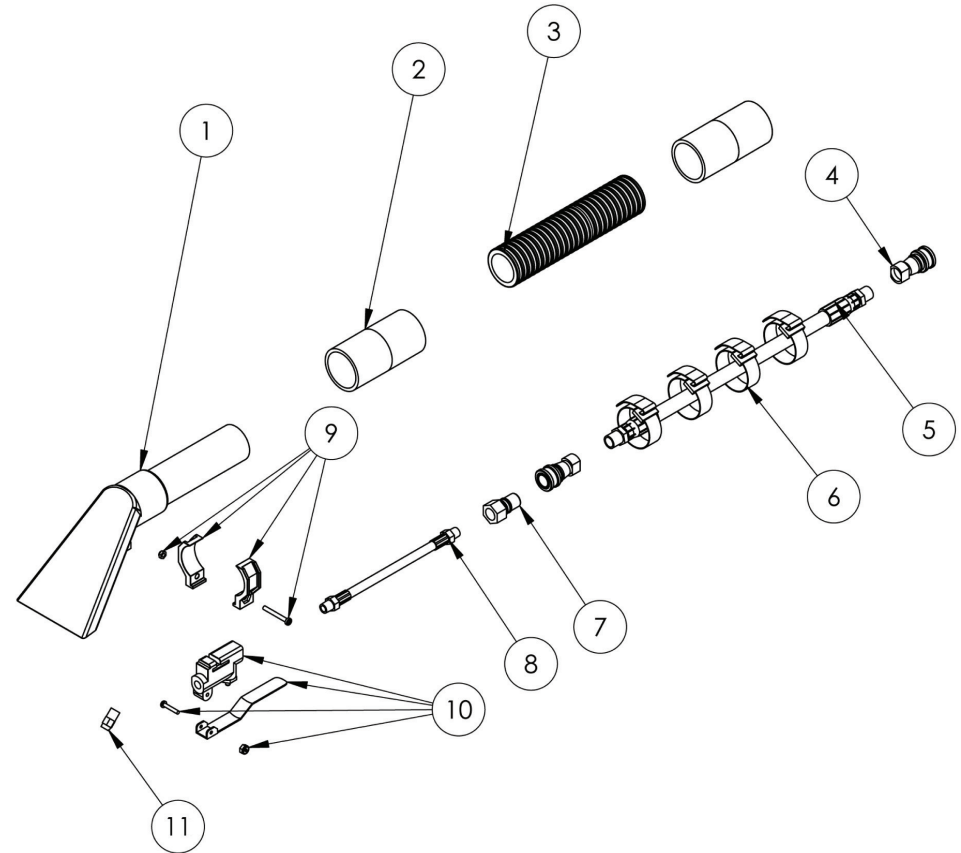

Parts List

Drawing No.	Item No.	Item Description	Qty. Needed
1	10-0501	4" Stainless Steel Upholstery Tool	1.00
2	10-0463	Black Slip Hose Cuff for Spotter	2.00
3	50-1008	15-Foot Black Hose 1-1/4"	1.00
4	10-0868	1/4" Female QD for Spotter	1.00
5	80-8007	1/4" x 15-Foot Extractor Hose	1.00
6	10-0388	Velcro Strap	1.00
7	10-0870	1/4" Male QD	1.00
8	10-0507	8" Black Hose for Stainless Steel Hand Tool	1.00
9	10-0506	Valve Clamp for Stainless Steel Hand Tool	1.00
10	10-0504	Valve for Stainless Steel Hand Tool	1.00
11	10-0502	Jet for Stainless Steel Hand Tool	1.00

5.0 Wiring Diagram

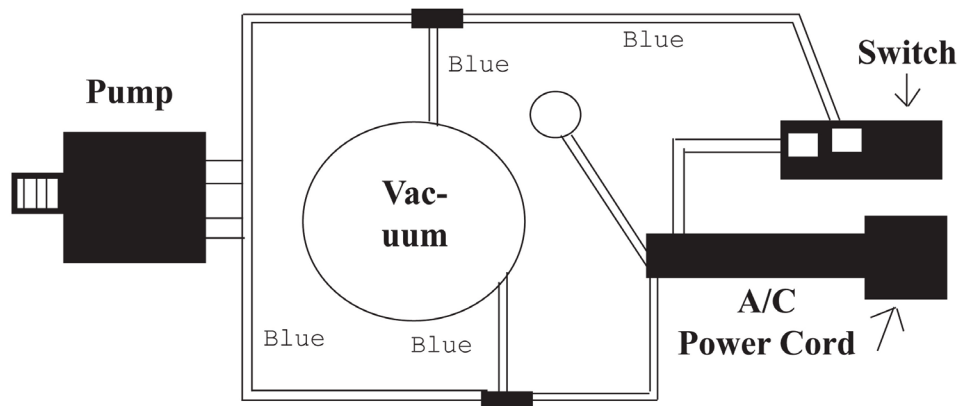

CAUTION – Electrical wire colors may vary. Determine start and end point of each wire to confirm connection point.

Returned Material Authorization (RMA) Procedure

Original purchaser must contact the manufacturer to follow correct RMA/warranty procedures. Must include a copy of RMA Sheet enclosed in the box with returned item. No returns shall be authorized unless the proper RMA procedures are followed. It is the responsibility of the distributor to repair the customer's equipment as soon as possible. If the distributor does not have the facilities to repair the equipment, it may be shipped or taken to an authorized service center for repair.

Customer must contact the manufacturer prior to working on or changing out any parts, etc. Manufacturer must issue an RMA Sheet containing approved labor time and replacement parts. Do not send parts or equipment back to manufacturer without an RMA Number and approval. No labor will be paid for, nor part costs paid for or reimbursed that have not been previously approved by the manufacture. All warranty work must be approved and authorized to qualify and appropriate warranty procedures must be followed.

1.0 Safety Instructions

WARNING: PLEASE READ AND SAVE! FOLLOW THESE PRECAUTIONS WHEN USING YOUR SPOT-TRACT.

- DO NOT operate this unit if any part of the unit appears to be damaged.
- DO NOT operate if ground plug is broken.
- DO NOT operate if the unit is in standing water.
- DO NOT use volatile substances or operate where volatile substances exist.
- DO NOT service while unit is running or connected to electricity. Unplug the unit!
- DO NOT use water more than 120 degrees Fahrenheit.
- DO NOT use solvents with this unit.
- DO NOT use as a dry vacuum.
- DO NOT use unit unless completely assembled.
- Use only liquid detergents. Powders do not fully dissolve and damage motor.
- Always use defoamer. Foam will suspend moisture particles that damage motor.

2.0 Set-Up / Prepare Unit for Use

DO NOT EXPOSE TO RAIN. STORE INDOORS.

- All spot extractors – no matter what the time of year – are shipped with antifreeze in the pump and solution lines. Prior to first use, fill the tank with one quart of warm water. Attach the hose and using the hand tool, flush out the system by spraying the one quart of water through the pump.
- Attach the 1-1/2 inch vacuum hose and the brass quick disconnect.
- Fill the base unit (the recovery tank must be removed) with warm water (less than 100 degrees Fahrenheit). Fill to approximately 4 inches from the top. Use a liquid detergent made for carpet cleaning or upholstery. Read and mix to the dilution ratios as directed.

2.0 Set-Up / Prepare Unit for Use Continued

- DO NOT turn heater on until the heater is full of water.
- NEVER run the vacuum only with the pump on for more than 3 minutes. Water/solution needs to run through pump at all times to keep the pump cool while in use. Failure to do so will void the warranty.
- Be sure to replace any filters back into the machine prior to use.
- Do not use citrus acid, buterol or harsh degreasers inside the machine.

Vacuum Shut-Off

The spot extractor is designed with a vacuum restrictor to reduce the vacuum when the recovery tank is full. When the vacuum is restricted, the liquid will not travel up the nozzle of the hand tool. The motor speeds up (the sound of the motor will change) and this is your warning to dispose of recovered solution. The restrictor is a foam float that slides up and down the vacuum tube in the recovery tank.



Following Each Use

Remove the vacuum hose from the upper body, un-clip, rotate latch on the back of the unit and remove the upper section of the spotter. Dispose of the used solution by pouring the solution out of the vacuum inlet (not the hatch cover) into the toilet or janitor's closet sink.

IMPORTANT!! Be sure to thoroughly drain water out of heater lines prior to storage in colder climates. This heater will freeze and possibly crack, voiding your warranty.

3.0 Problem Solving

Never operate this spot extractor when the equipment is not performing as expected or when any part is visibly damaged. When repair is needed, take the equipment to an authorized service center.

Spotter will not run

- Check power connection. Move the grounded plug to an outlet that is working. Verify that the plug is working by plugging in another electrical component such as lamp, hair dryer or drill.
- Inspect the power cord for damage.

Loss of vacuum

- Make sure the float is at the bottom of the unit. Open the screw cap and push the float down.
- Check that the hose cuff is securely attached to the front of the extractor.

3.0 Problem Solving Continued

Loss of solution pressure

- Verify that the pump is on. Remove jet from end of hand tool and press trigger on wand.
- Clean the solution intake in the solution tank. Check quick-disconnect for debris.
- If pump is still not working, seek authorized repair services.

4.0 Grounding Instructions

DANGER: IMPROPER GROUNDING METHOD CAN RESULT IN A RISK OF ELECTRIC SHOCK.

Electrical equipment must be grounded. If the machine should malfunction or breakdown, grounding provides a path of least resistance for electrical current to reduce the risk of electric shock. The Carpet Extractor is equipped with a cord containing a grounding conductor and grounding plug. The plug must be inserted into an appropriate outlet that is properly installed and grounded in accordance with all local codes and ordinances.

If repair or replacement of the cord or plug is necessary, DO NOT connect the grounded wire to a flat bed terminal. The grounding wire is the wire with insulation and an outer green surface, with or without yellow stripes.

Grounding Method

The equipment is for use on a normal 120 Volt circuit. It includes a grounded plug (plug shown in Figure A). A temporary adaptor (Figure B and C) may be used to connect this plug into a 2-pole receptacle (Figure B) if a properly grounded outlet is not available.

The temporary adaptor should be used only until a properly grounded outlet (Figure A) can be installed by a qualified electrician. The green colored rigid ear lug or the like extending from the adaptor must be connected to a permanent ground, such as a properly grounded outlet box cover. Whenever an adaptor is used, it must be held in place by a metal screw.

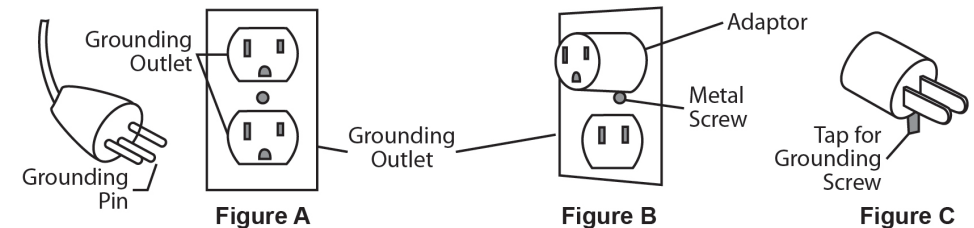

WARNING:

Improper connection of the equipment grounding conductor can result in a risk of electric shock. Check with a qualified electrician or service person if you are in doubt as to whether the outlet is properly grounded. DO NOT modify the plug provided with the equipment. If the plug will not fit into the outlet, have a proper outlet installed by a qualified electrician.

NOTE: In Canada, the use of a temporary adaptor is not permitted by the Canadian Electrical Code.